

NP SERIES - NP2-12

Reliability is your Security

Yuasa NP, NPC and NPH Batteries. Utilising the latest advance design Oxygen Recombination Technology, Yuasa have applied their 80 years experience in the lead acid battery field to produce the optimum design of Sealed Lead Acid batteries.

FEATURES

- Superb recovery from deep discharge.
- Electrolyte suspension system.
- Gas Recombination.
- Multipurpose: Float or Cyclic use.
- Usable in any orientation (except continuous inverted).
- Superior energy density.
- Lead calcium grids for extended life.
- Manufactured World wide.
- Application specific designs.

Technical Features

Sealed Construction

Yuasa's unique construction and sealing technique ensures no electrolyte leakage from case or terminals

Electrolyte Suspension System

All NP batteries utilize Yuasa's unique electrolyte suspension system incorporating a microfine glass mat to retain the maximum amount of electrolyte in the cells. The electrolyte is retained in the separator material and there is no free electrolyte to escape from the cells. No gels or other contaminants are added.

Control of Gas Generation

The design of Yuasa's NP batteries incorporates the very latest oxygen recombination technology to effectively control the generation of gas during normal use.

Low Maintenance Operation

Due to the perfectly sealed construction and the recombination of gasses within the cell, the battery is almost maintenance free.

Layout

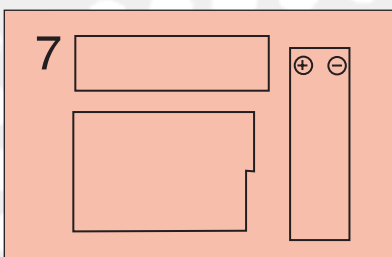

Terminals

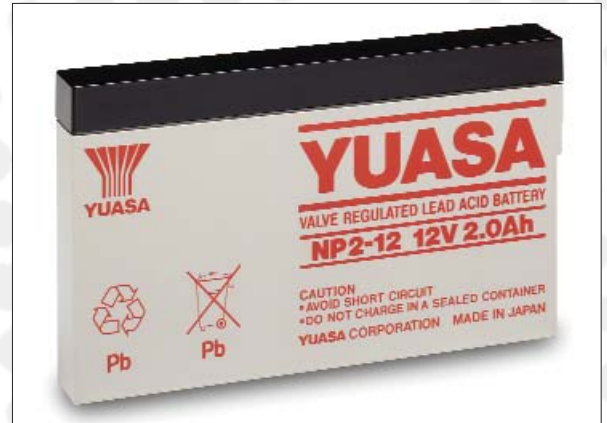
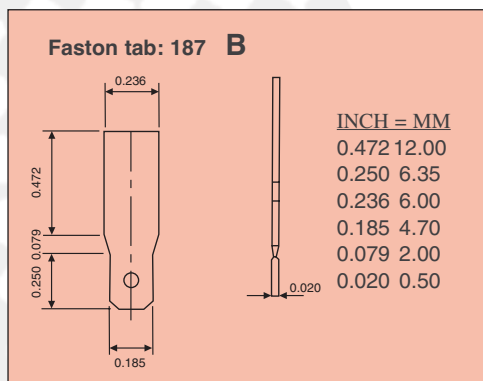

Terminals

NP batteries are manufactured using a range of terminals which vary in size and type. Please refer to details as shown.

Operation in any Orientation

The combination of sealed construction and Yuasa's unique electrolyte suspension system allows operation in any orientation, with no loss of performance or fear of electrolyte leakage. (Excluding continuous use inverted)

Valve Regulated Design

The batteries are equipped with a simple, safe low pressure venting system which releases excess gas and automatically reseals should there be a build up of gas within the battery due to severe overcharge. Note. On no account should the battery be charged in a sealed container.

General Specifications

Nominal Capacity (Ah)	NP2-12
20hr to 1.75vpc 20°C	2
10hr to 1.75vpc 20°C	1.86
5hr to 1.70vpc 20°C	1.7
1hr to 1.60vpc 20°C	1.2
Voltage	12
Energy Density (Wh.L.20hr)	95
Specific Energy (Wh.kg.20hr)	34
Int. Resistance (m.Ohms)	180
Maximum discharge (A)	10
Short Circuit current (A)	30
Dimensions (mm)	
Length	150
Width	20
Height overall	89
Weight (Kg)	0.7
Terminal	B
Layout	7
Terminal Torque Nm	-

Lead Calcium Grids

The heavy duty lead calcium alloy grids provide an extra margin of performance and life in both cyclic and float applications and give unparalleled recovery from deep discharge.

Long Cycle Service Life

Depending upon the average depth of discharge, over a thousand discharge/charge cycles can be expected.

Float Service Life

The expected service life is five years in float standby applications.

Separators

The use of the special separator material provides a very efficient insulation between plates preventing inter-plate short circuits and prohibiting the shedding of active materials.

Long shelf Life

The extremely low self discharge rate allows the battery to be stored for extended periods up to one year at normal ambient temperatures with no permanent loss of capacity.

Operating Temperature Range

The batteries can be used over a broad temperature range permitting considerable flexibility in system design and location.

Charge – 15°C to 50°C

Discharge – 20°C to 60°C

Storage – 20°C to 50°C (fully charged battery)

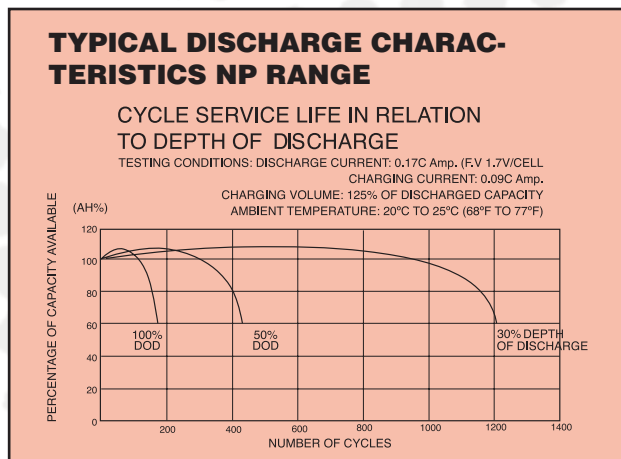
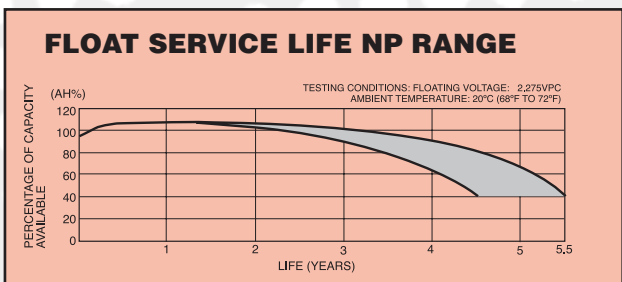
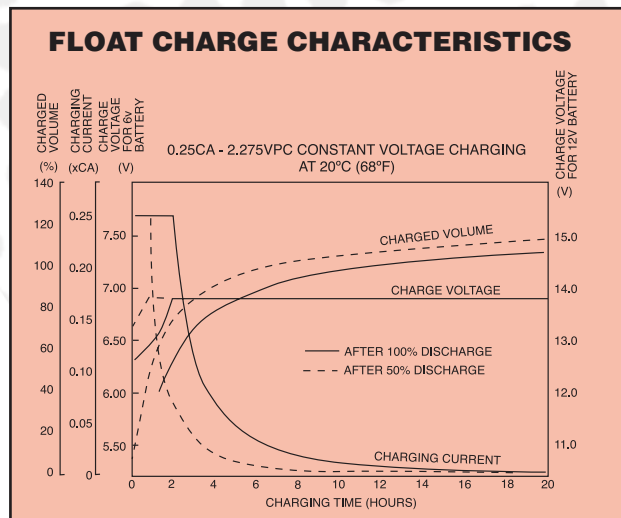
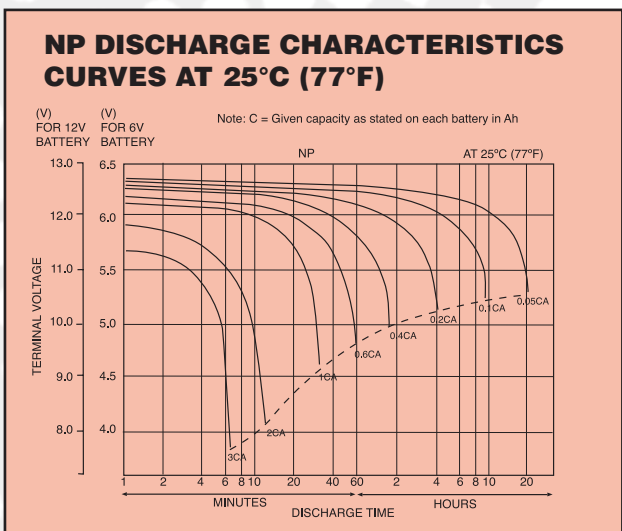
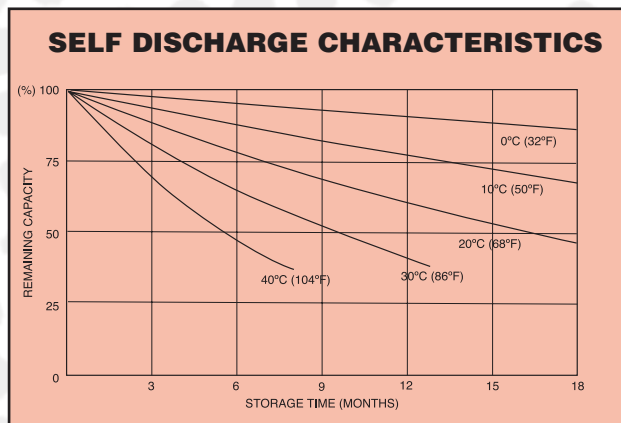
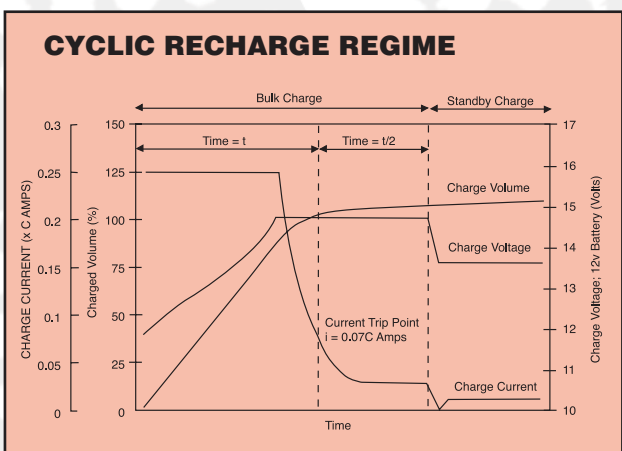

INTELLIGENT BATTERY CHARGERS

Manufactured to BS3456, IEC335, UL 1236, EN60335, CE mark to EN5008-1

Features

- Micro processor controlled
- Short circuit protection
- Reverse polarity protection
- High temperature protection
- Soft start current control
- Fast constant current bulk charge
- 3 stage charging CI-CV-float
- Constant voltage float/standby
- Proportional timing
- Flexibility, to match battery specification.

Standard Range

YCP03A12	300mA 12v
YCP03A24	300mA 24v
YCP03A6	300mA 6v
YCP06A12	600mA 12v
YCP06A6	600mA 6v
YCP1.5A12	1.5A 12v
YCP1.5A24	1.5A 24v
YCP1.5A6	1.5A 6v
YCP1A12	1A 12v
YCP1A6	1A 6v
YCP2A12	2A 12v
YCP2A24	2A 24v
YCP2A6	2A 6v
YCP3A12	3A 12v
YCP4A12	4A 12v
YCP6A12	6A 12v
YCP8A12	8A 12v
YCP10A12	10A 12v
YCP8A24	8A 24v

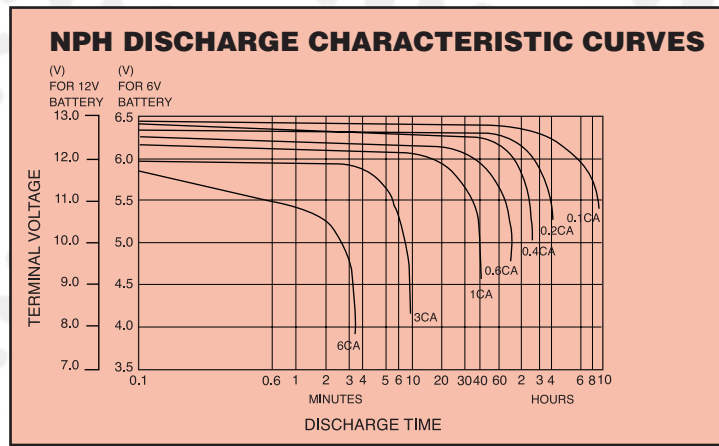

Standard NP

Available in a wide range of sizes to suit general applications.

NPH/NPW

High performance batteries specially designed for applications requiring high rate discharge, supplying up to 50% (NPH), (NPW) more power (Watts) for short durations when compared to conventional NP models.

NPC

Specifically designed to suit the arduous requirements of cyclic applications allowing increased cycle life (at least double that of conventional types). (NPC Shortform refers)

NPL

Long Life Model also to BS6290pt4 (FR Options)
Dedicated literature available on request. (NPL Shortform refers).

Applications

Yuasa NP batteries, having excellent deep discharge recovery characteristics coupled with long life on float standby, are ideal for numerous applications in both cyclic and standby modes. For advice on the use of NP batteries in your particular application please contact our Sales Office.

Charging For Float Standby Applications

Charged at 2.275 volts per cell continuous. The battery will seek its own current level and float fully charged. However, users should be aware that when charging from fully discharged, the battery can draw an initial charge current of approximately 2cA. Care should therefore be taken to ensure that this initial charge current (if uncontrolled) is within the output capability of the equipment. Final charge current at 2.275 volts per cell is typically between 0.0005cA to 0.004cA.

Charging For Cyclic Applications

See cyclic recharge regime graph.

CAUTION

- Do not Short Circuit
- Do not charge in a sealed container
- Service life and operational characteristics will be affected by temperature
- AC Ripple reduces service life.

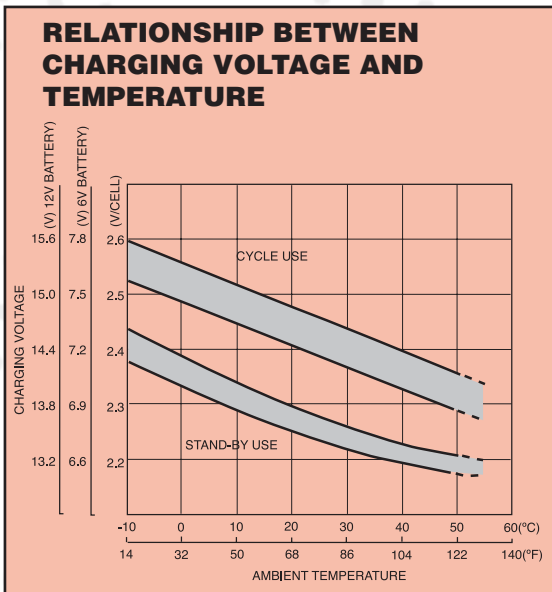

Yuasa Battery Sales (UK) Ltd

Unit 22 Rassau Industrial Estate
Ebbw Vale, Gwent, NP23 5SD
Tel: 08708 500312 Fax: 08708 500317
E-mail: enquiries@yuasa-sales.co.uk

Registered number 1548820

Cat. No. NP2-12 February 07

E&O.E.

Distributed by