

Powered by



GP 12650 ▶ 12V 65Ah

GP 12650 is a general purpose battery up to 5 years in standby service or more than 260 cycles at 100% discharge in cycle service. As with all CSB batteries, all are rechargeable, highly efficient, leak proof and maintenance free.



► Specification

Cells Per Unit	6
Voltage Per Unit	12
Capacity	65A h @ 20hr-rate to 1.75V per cell @25 °C(77°F)
Weight	Approx. 20 kg(44.09 lbs)
Maximum Discharge Current	500A(5sec)
Internal Resistance	Approx. 8 m Ω
Operating Temperature Range	Discharge: -15°C~50°C (5°F~122°F) Charge: -15 °C~40°C (5°F~104°F) Storage: -15°C~40°C (5°F~104°F)
Nominal Operating Temperature Range	25°C±3°C(77°F±5°F)
Float Charging Voltage	13.5 to 13.8 VDC/unit Average at 25°C(77°F)
Recommended Maximum Charging Current Limit	19.50A
Equalization and Cycle Service	14.4 to 15.0 VDC/unit Average at 25°C(77°F)
Self Discharge	CSB Batteries can be stored for more than 6 months at 25°C(77°F). Please charge batteries before using. For higher temperatures the time interval will be shorter.
Terminal	B4-L terminal to accept M6 nut & bolt
Container Material	Polypropylene(UL 94-V0/File E50955)*Flammability resistance of (UL 94-HB/File E216959) can be available upon request.



CSB-manufactured batteries are UL-recognized components under UL924 and UL1989. CSB is also certified by ISO 9001 and ISO 14001.

► Dimensions :

Unit: mm (inch)

Overall Height (H)	Container height (h)	Length (L)	Width (W)
174±2 (6.85±0.08)	172.5±2 (6.79±0.08)	349.9±2.5 (13.75±0.1)	166±2 (6.53±0.08)

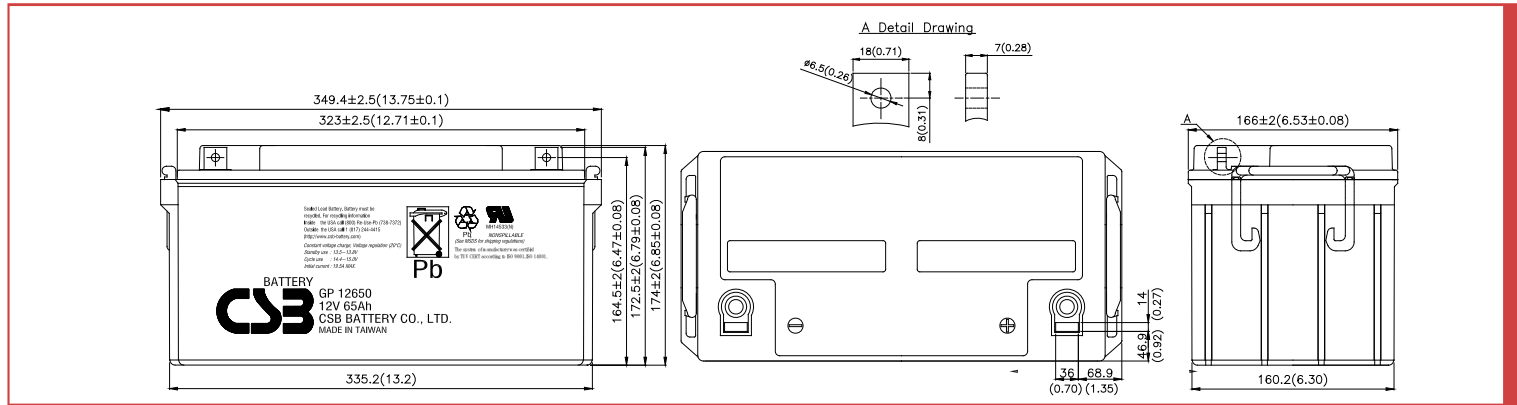

Constant Current Discharge Characteristics Unit:A (25°C, 77°F)

F.V/Time	5MIN	10MIN	15MIN	30MIN	1HR	2HR	3HR	4HR	5HR	8HR	10HR	20HR
1.60V	271	173	132	79.9	47.2	27.3	19.4	15.1	12.4	8.08	6.58	3.57
1.67V	242	162	124	78.3	46.9	27.2	19.3	15.0	12.3	7.98	6.48	3.42
1.70V	229	157	121	77.3	46.7	27.1	19.2	14.9	12.2	7.93	6.43	3.36
1.75V	208	147	117	75.4	46.4	27.0	19.1	14.8	12.1	7.86	6.32	3.25
1.80V	186	137	111	73.4	45.9	26.9	19.0	14.7	12.0	7.76	6.21	3.14
1.85V	164	127	105	71.3	45.4	26.8	18.9	14.6	11.9	7.66	6.10	3.03

Constant Power Discharge Characteristics Unit:W (25°C, 77°F)

F.V/Time	5MIN	10MIN	15MIN	30MIN	1HR	2HR	3HR	4HR	5HR	8HR	10HR	20HR
1.60V	3,250	2,080	1,580	959	566	327	232	181	148	97.0	79.0	40.9
1.67V	2,900	1,940	1,503	935	562	326	231	180	147	96.0	77.7	39.2
1.70V	2,750	1,871	1,460	924	560	325	230	179	146	95.5	77.1	38.4
1.75V	2,490	1,760	1,400	903	555	324	229	178	145	94.3	75.8	37.1
1.80V	2,230	1,640	1,330	881	550	323	228	177	144	93.1	74.5	35.7
1.85V	1,970	1,520	1,260	856	545	322	227	176	143	91.9	73.2	34.4

Trickle (or Float) Service Life

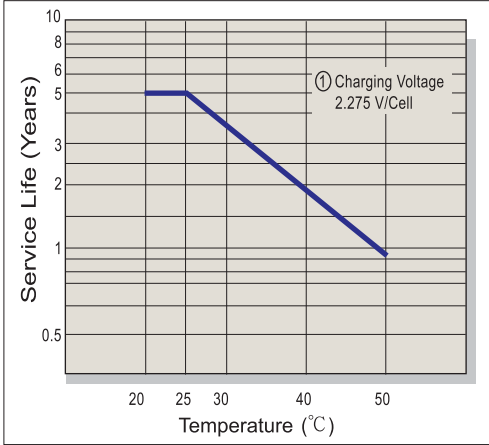

Capacity Retention Characteristic

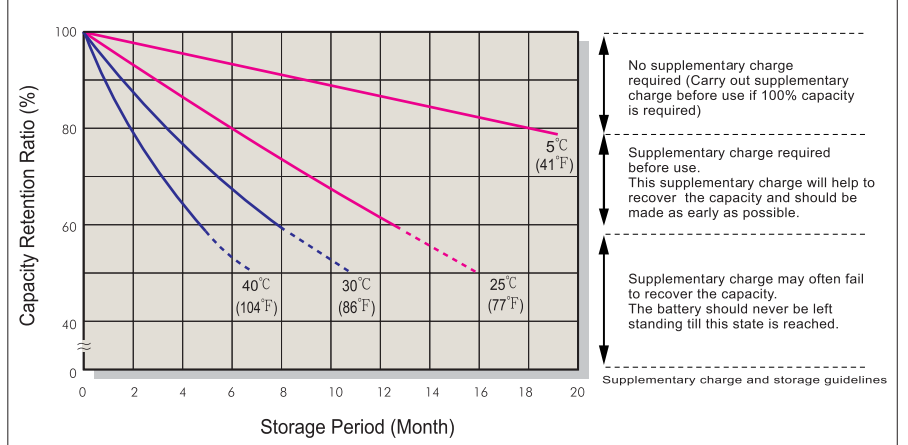

Battery Voltage and Charge Time for Standby Use

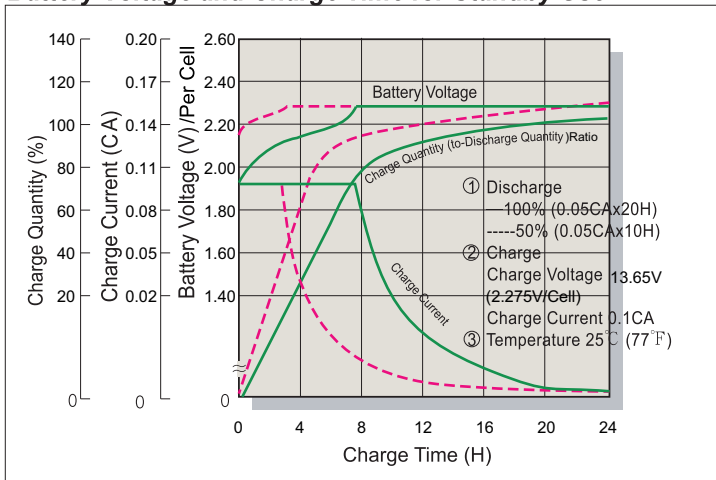

Cycle Service Life

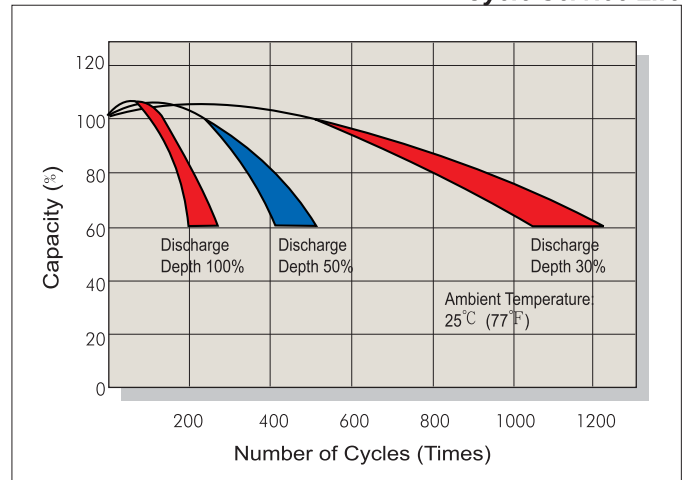

Battery Voltage and Charge Time for Cycle Use

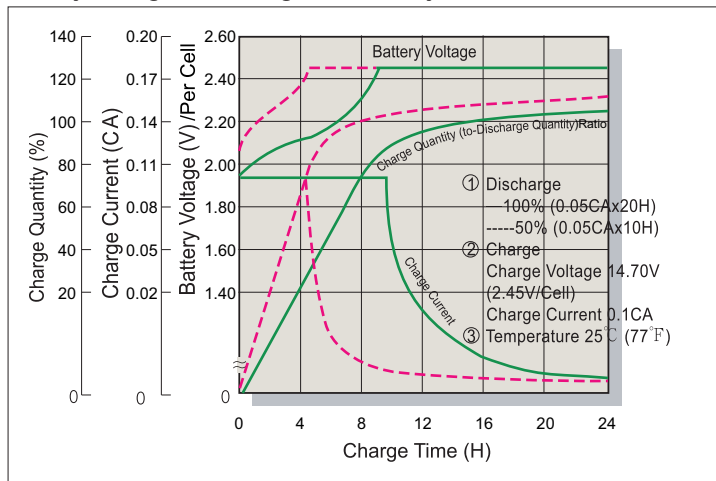

Terminal Voltage (V) and Discharge Time

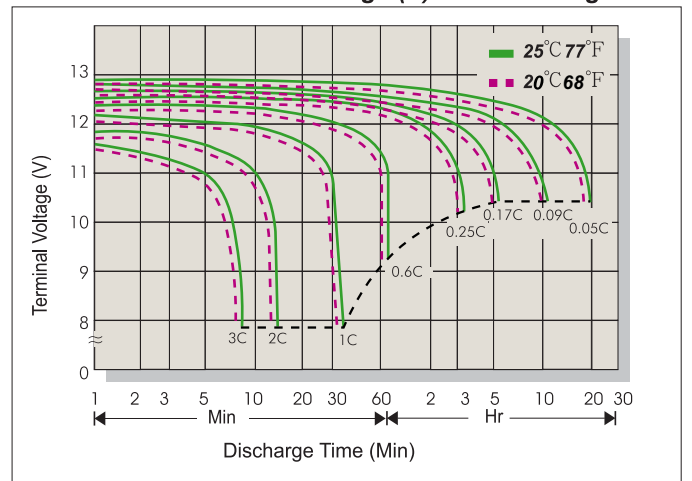

Charging Procedures

Application	Charge Voltage(V/Cell)			Max.Charge Current
	Temperature	Set Point	Allowable Range	
Cycle Use	25°C (77°F)	2.45	2.40~2.50	0.3C
Standby	25°C (77°F)	2.275	2.25~2.30	

Discharge Current VS. Discharge Voltage

Final Discharge Voltage V/Cell	1.75	1.70	1.60	1.30
Discharge Current(A)	0.2C>(A)	0.2C<(A)<0.5C	0.5C<(A)<1.0C	(A)>1.0C

Sales Office URL: WWW.CSB-BATTERY.COM

CSB BATTERY CO., LTD.
TAIWAN OFFICE
Tel: +886-2-2555-5600
Fax: +886-2-2555-3300
E-mail: service@csb-battery.com.tw

CSB BATTERY LOGISTICS (SHANGHAI) CO., LTD.
SHANGHAI OFFICE
Tel: +86-21-5046-1622, 5046-0833
Fax: +86-21-5064-3314
E-mail: chinasl@csb-battery.com

CSB BATTERY TECHNOLOGIES, INC
USA OFFICE
Tel: +1-817-244-7777/1-8003 CSBUSA(272872)
Fax: +1-817-244-4445
E-mail: csb@csb-battery.com

CSB BATTERY LOGISTICS (SHANGHAI) CO., LTD.
BEIJING OFFICE
Tel: +86-10-6597-8060, 6597-8070
Fax: +86-10-6597-8050
E-mail: chinasl@csb-battery.com

CSB BATTERY OF NETHERLANDS B.V
EUROPE OFFICE
Tel: +31(0)180 418 140
Fax: +31(0)180 418 327
E-mail: eurosales@csb-battery.eu

CSB BATTERY LOGISTICS (SHANGHAI) CO., LTD.
SHENZHEN OFFICE
Tel: +86-755-8831-6488/6396/16356
Fax: +86-755-8831-6548
E-mail: she@csb-battery.com.cn